

Hexalobular socket pan head screws

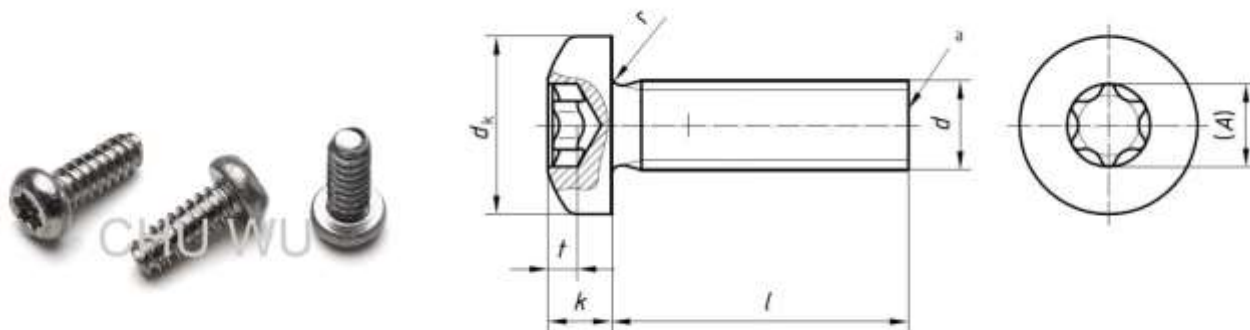

Unit : mm

Nom. dia. (d)	Pitch (P)	Head diameter (dk)	Head height (k)	Recess (A)	Penetration gauging depth (t)
M6	1.0	12	4.6	T30	2.42
M5	0.8	9.5	3.7	T25	1.91
M4	0.7	8	3.1	T20	1.66
M3.5	0.6	7	2.6	T15	1.33
M3	0.5	5.6	2.4	T10	1.27
M2.5	0.45	5	2.1	T8	1.04
M2	0.4	4	1.6	T6	0.77
M1.6	0.35	For more information, please contact our sales staff			
M1.4	0.3				
M1.2	0.25				
M1	0.25				

Standard per ISO 14583



CHU WU INDUSTRIAL CO., LTD.

No. 16, Guanghua Rd., Sanchong Dist., New Taipei City 241, Taiwan
 Tel: +886-2-8512-4735(Rep.) Fax: +886-2-8512-4295, 8512-4737
 E-mail: sales@chuwu.com.tw http://www.chuwu.com.tw