

# JIS B1188 Screw with spring lock washer and flat washer

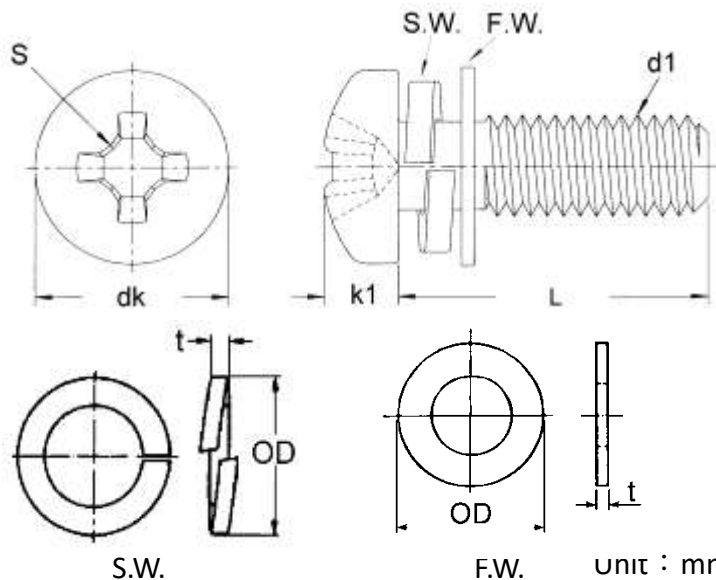

Thread size (d1)	Pitch (P)	Head diameter (dk)	Head height (k1)	Drive Size (S)	S.W		F.W	
					(OD)	(t)	(OD)	(t)
M2	0.4	3.5	1.3	NO.1	4	0.5	4.3	0.3
M2.5	0.45	4.5	1.7	NO.1	4.8	0.6	5	0.5
M3	0.5	5.5	2	NO.2	5.5	0.7	6	0.5
M4	0.7	7	2.6	NO.2	7	1	8	0.8
M5	0.8	9	3.3	NO.2	8.5	1.3	10	1.0
M6	1.0	10.5	3.9	NO.3	11.5	1.5	11.5	1.6
M8	1.25	14	5.2	NO.3	14.5	2	15.5	1.6

There is no restriction on the application of head type in picture content. For more information, welcome to contact us.