

# DIN6900 Part 2 Screw with wave spring washer

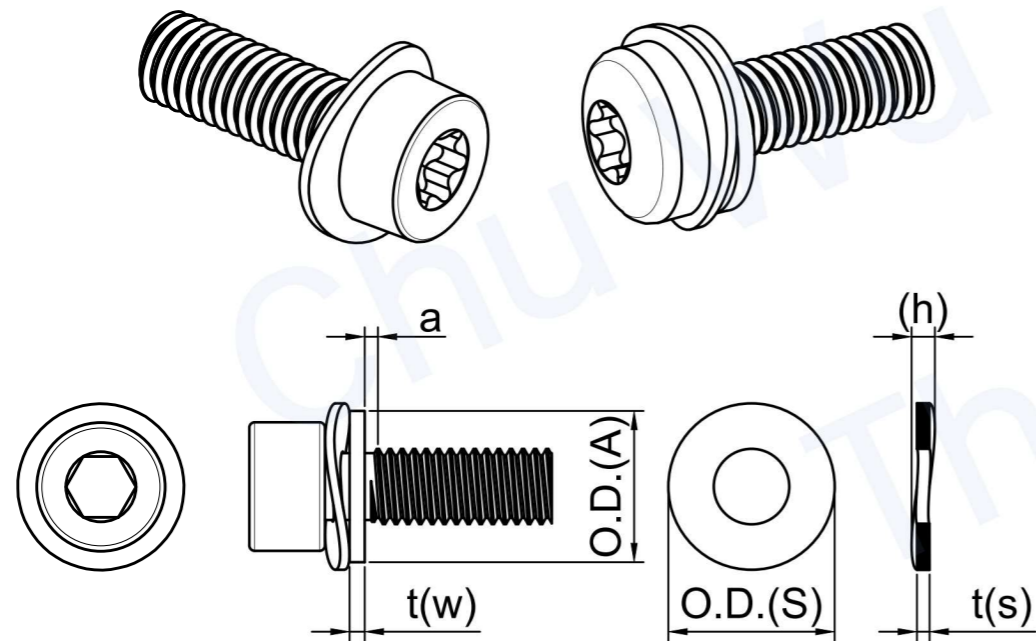

Unit: mm

Thread size	Pitch	a (max.)	Wave spring washer (DIN6904)			Flat Washer (DIN6902)			
			O.D.(S)	t(s)	Height(h)	Type A		Type B	
						O.D.(A)	t (w)	O.D.(A)	t (w)
M8	1.25	2.50	15.00	1.00	2.40	16.00	2.00	24.00	2.00
M6	1.00	2.00	12.00	0.80	2.00	12.00	1.60	18.00	1.60
M5	0.80	1.60	11.00	0.80	1.75	10.00	1.00	15.00	1.60
M4	0.70	1.40	9.00	0.80	1.65	9.00	0.80	12.00	1.00
M3	0.50	1.00	8.00	0.50	1.05	7.00	0.60	9.00	0.80
M2.5	0.45	0.90	7.00	0.50	1.05	6.00	0.60	8.00	0.80



There is no restriction on the application of head type in picture content. For more information, welcome to contact us.